

Connection Instructions for 34B/SR-WX Gearmotors Remote Operation In Non-Hazardous Locations

This application note explains the steps to properly wire our standard **34B/SR-WX**, 12/24VDC gearmotors for remote operation in a non-hazardous location. For remote operation of these products in a Class I, Division 2, Groups A, B, C, or D hazardous environment, please review your local safety rules and regulations. Contact our technical support team at 773-478-3515, or via info@bodine-electric.com.

Connections for Remote Operation

To prepare the control for remote connections, first remove the 8-pin connector from plug-in receptacle J4 on the control PCB.

If the speed will be controlled remotely, cut all of speed potentiometer wires as close to the terminals as possible.

Connecting an External Speed Potentiometer

A10 KΩ potentiometer can be used to remotely control gearmotor speed (for applications where the built-in speed potentiometer can't be accessed). Clockwise rotation of the potentiometer increases gearmotor speed when connected as follows:

- Solder three leads of appropriate length to the potentiometer.
- Terminate the other ends of the potentiometer leads with the pins supplied with the 8-pin interface connector.
- Mount the potentiometer in the desired location.
- Refer to Figure 1 and insert the potentiometer leads into the interface connector as follows:
 - High side (CW terminal) of the potentiometer to interface terminal VRF (J4, Pin 1)
 - Low side (CCW terminal) of the potentiometer to interface terminal COM (J4, Pin 3)
 - Center terminal of the potentiometer to interface terminal VIN (J4, Pin 2)
- The Max Speed (MX) potentiometer on the control board may be used to limit the maximum gearmotor speed obtainable with the control.

Table 1 – J4 Connection Description

Pin 1	Pin 2	Pin 3	Pin 4	Pin 5	Pin 6	Pin 7	Pin 8
VRF	VIN	COM	ENÄ		DIR	BRK	TACH

Pin type: Molex 22-11-2052

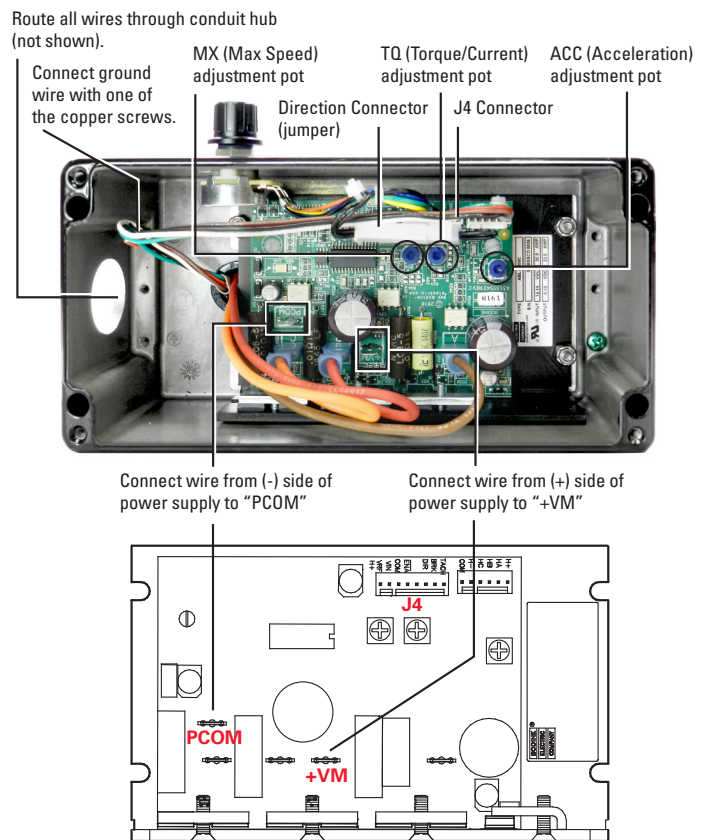

Figure 1 – Location of Control Components and Connections

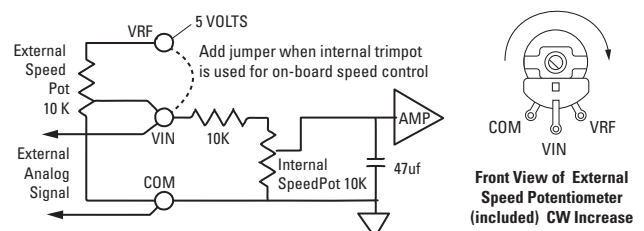

Figure 2 – Internal and External Speed Potentiometer Connections

Controlling Speed with an Analog Input Voltage

Gearmotor speed can be controlled with a 0 to 5 VDC analog input signal (for applications where the gearmotor and control are part of a larger control system). Apply the 0-5 VDC signal across the VIN and COM terminals of the interface connector J4. Refer to Figure 2. Speed is increased by increasing the voltage level applied to VIN (Pin J4-2). 0 VDC = 0 RPM; 5 VDC = Max. RPM. This input may be configured for either internal or external speed command operation. If the gearmotor/control system is part of a larger motion control system, the speed may be controlled by a microprocessor or PLC, provided a digital to analog converter is used to interface the output of the system control and the speed input of the 34B/SR-WX control.

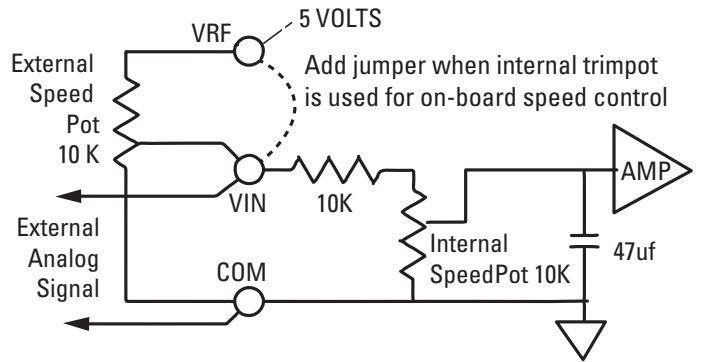

Figure 2 – Internal and External Speed Potentiometer Connections

Control Logic Connections

⚠ WARNING

Never rely on logic circuitry as a means of disabling the gearmotor or control. To prevent unsuspected mechanical motion and potential injury, the AC power should always be disconnected from the control power supply whenever logic circuits or the driven equipment are serviced. When a battery is used, the DC supply to the control should be disconnected.

Manual switches, relays, or logic signals can be used to control gearmotor braking, enable, and direction of rotation. Figure 3 shows the pin-out of the interface connector J4, as well as interface information for the logic inputs. Table 2 lists the condition of the control input based on the open or closed condition of the relay contact or switch and the high or low state of the input signal.

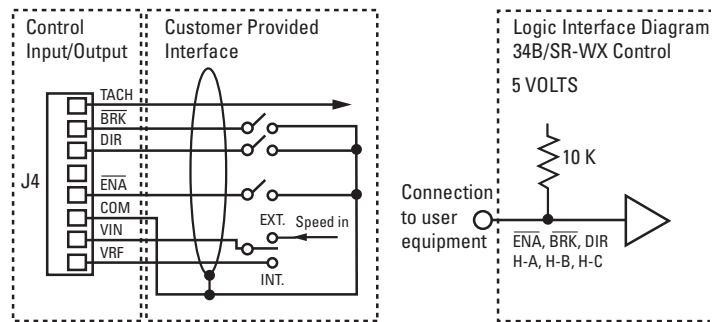

Figure 3 – Control Logic Inputs

Table 2 – Pin-Out and Logic State of Control Inputs

Designation	Closed-Switch or Low Voltage State ¹	Open-Switch or High Voltage State ¹
ENA ²	Drive Enabled	Drive Disabled
DIR ³	CCW Direction	CW Direction
BRK	Brake	Run

1. Logic Low=0.0-0.4 V; Logic High=3.0-5.0 V

2. When ENA goes high the gearmotor will coast to a stop

3. The output shafts of gearmotors with odd number of stages (for example, Bodine type designations ending with WX3) will rotate in the opposite direction. A "Smart Reverse Circuit" prevents plug reversing if the switch is opened or closed while the gearmotor is running. The gearmotor will coast to low speed before changing direction. However, it is best to stop the gearmotor before changing the DIR input to avoid overspeeds when accelerating back to the set speed.

Tachometer Connection

The 34B/SR-WX control provides a digital tachometer output at the TACH terminal (J4, Pin 8) for monitoring gearmotor speed. The 5 VDC output pulse levels are low to high to low. The pulse width is fixed at 0.55 msec each. Twelve pulses correspond to one gearmotor revolution. The buffered output requires no external pull-up resistor to produce the 5 VDC pulses. If the user prefers an analog voltage tachometer signal instead of digital pulses, the average voltage from the TACH output is directly proportional to gearmotor speed. An external filter or averaging circuit is needed to read the digital output as an analog 0-5 VDC output.

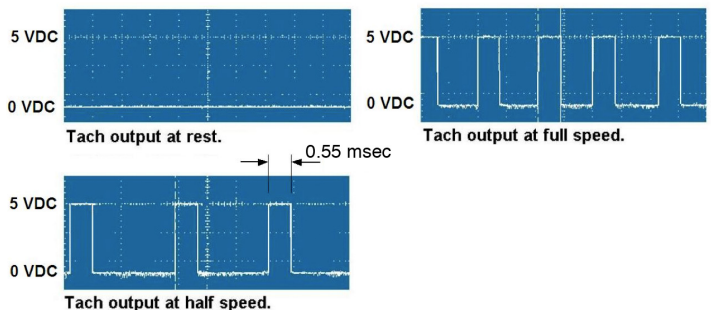

Figure 4 – Snapshots of three scope readouts showing the TACH output signal at three different gearmotor speeds.